

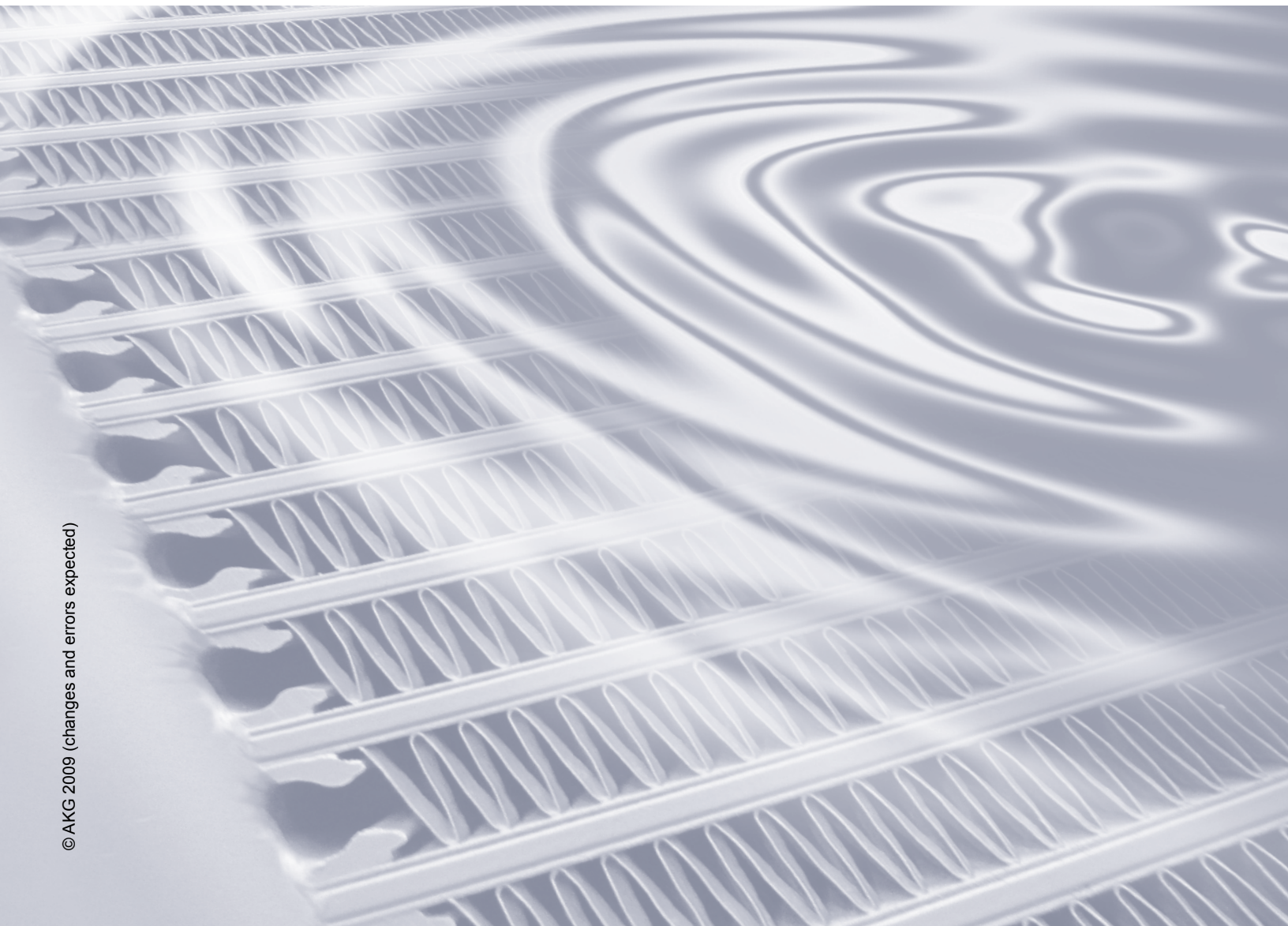

GLOBAL STANDARD COOLER

Cool-Line

H



OIL-TO-AIR COOLING SYSTEMS WITH HYDRAULIC MOTOR

PRODUCT INFORMATION

AKG Cool-Line is a standard line of products from the market leader in high performance aluminum cooling systems. AKG is best known for its world-wide presence, German engineering and extremely reliable product quality on the one hand and very competitive prices on the other hand.

The Cool-Line type series consist of different models for mobile and stationary applications and are available through our global specialist dealer network. This line of products embraces all-purpose complete cooling systems that comply with European or American Standards, is suited for normal or rugged environmental operating conditions, is powered by AC-, DC- or hydraulic-motor-driven fans and is also available with noise-optimized models.

All of AKG's solutions have been developed with state-of-the-art technology, produced in compliance with the highest quality standards and are comprehensively tested in the company's own research and test facility.

FEATURES OF THE H SERIES:

- High-Performance cooling assemblies
- Hydraulic motor powered fan
- The heat is transferred from the medium to be cooled to the ambient air
- Cooler can be universally used in hydraulic oil, transmission oil, engine oil, lubricating oil and coolant circuits
- For the cooling of mineral oil, synthetic oil, biological oil as well as of HFA, HFB, HFC and HFD liquids and water with at least 50 per cent of antifreeze and anticorrosive additives (other media available)
- Can be exposed to operating pressures of up to 26 bar or 17 bar, depending on model

BENEFITS:

- Highly flexible complete, ready-to-use cooling packages
- Compact and robust design, field-tested during many years of use in rugged real life conditions
- Largest and most comprehensive series of industrial and mobile hydraulic coolers
- Best heat transfer results per given cooler size due to comprehensive research and development
- Highest quality due to professional engineering and in-house manufacturing
- Available from stock or at short notice
- As a standard, equipped with AKG's patented double-life hollow sections designed to increase cooler service life
- As a standard feature, available with louvered high-performance air fins or alternatively with non-louvered low fouling cooling air fins (HR-Series)

H-Series FEATURES/BENEFITS

- New H optimized series coolers with louvered fin design provides the best HEAT TRANSFER per given cooler size in the industry.
- New H optimized series coolers offer increased performance with lower pressure drop than current same size AKG THERMAL SYSTEMS HC SERIES COOLERS.
- New H optimized series coolers have proprietary R & D designed, engineered and tested internal and external fins unique to AKG THERMAL SYSTEM coolers.
- All H series coolers are available with internal pressure BYPASS option.
- New H optimized series coolers offer the largest, most comprehensive cooler size ranges with competitive pricing and deliveries from stock.

PATENTED FLEXIBLE AKG HOLLOW PROFILE



Cool-Line uses patented AKG hollow profiles to reduce local peak strains. This way the strength of heat exchangers is significantly increased and their service life time considerably prolonged.

AKG HOLLOW PROFILE FEATURES:

- **Reduced Strain:**
Strength calculations show that when using AKG hollow profiles maximum strain is reduced by a factor of 2
- **Prolonged Service Life Time:**
Extensive rig tests have shown that service life time increases by a factor ranging from 3 to 5

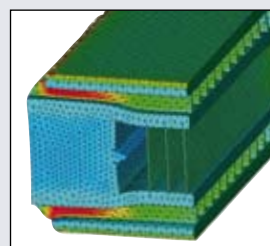

with standard profile

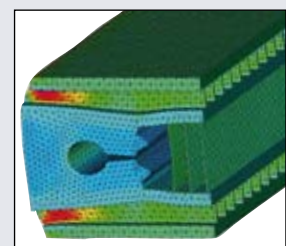

with hollow profile

PERFORMANCE DATA (H SERIES @ 1750 RPM FAN SPEED)

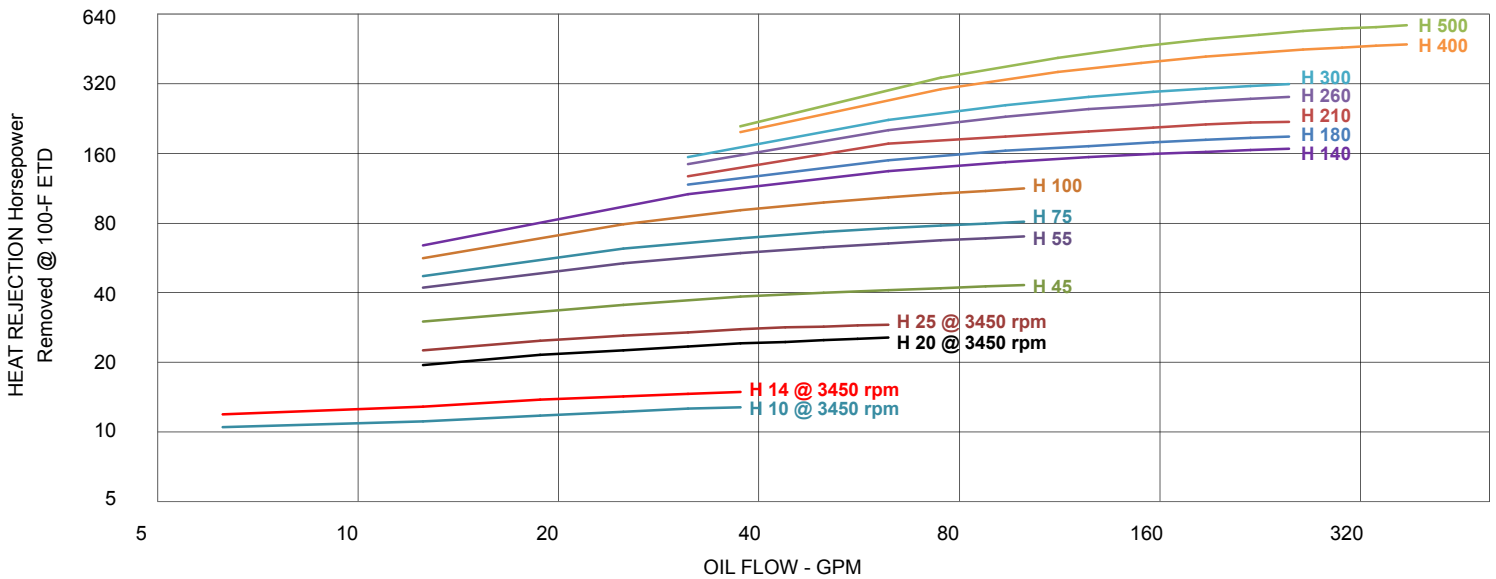

Specifications:

| | |
|--|---------|
| Maximum Working Pressure (H10 through H260) | 377 PSI |
| Maximum Working Pressure (H300 through H500) | 250 PSI |
| Maximum Working Temperature | 250 °F |

Materials:

| | |
|-------------------|-----------------------------------|
| Cooler | Aluminum |
| Shroud | Power Painted Steel |
| Fan Guard | Zinc Plated Steel |
| Fan Blade | Polypropylene Blades Aluminum Hub |
| Mounting Brackets | Powder Painted Steel |

PERFORMANCE DATA (H SERIES @ 1140 RPM FAN SPEED)

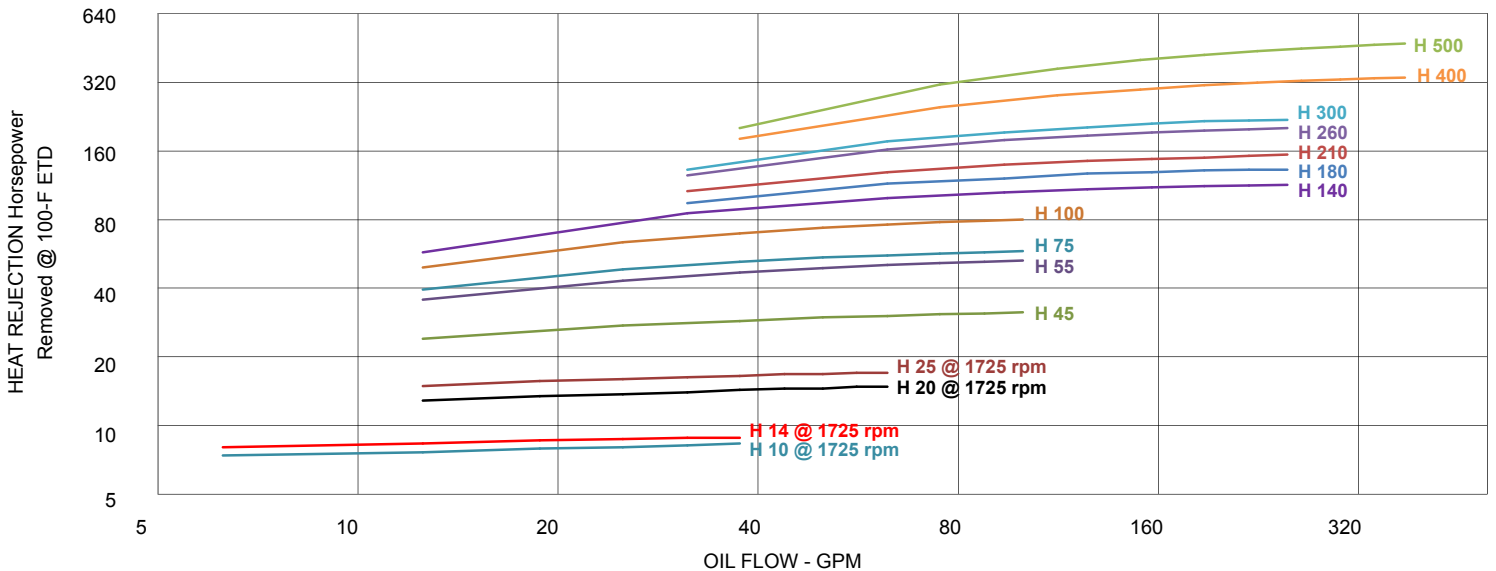



H SERIES TECHNICAL DATA

| Model Size | Motor Size (cubic in.) | Operating Speed (RPM) | Motor Flow Rate @ Operating Speed (gpm) | Motor Pressure @ Operating Speed (psi) | Motor Max Pressure (psi) | Approx. Noise Level (dB(A), 1 m) | Working Pressure (psi) | Approx. Shipping Weight (lbs) |
|------------|------------------------|-----------------------|---|--|--------------------------|----------------------------------|------------------------|-------------------------------|
| H10 | 0.218 | 3450/1725 | 3.6/1.8 | 500 | 2000 | 77/65 | 377 | 30 |
| H14 | 0.218 | 3450/1725 | 3.6/1.8 | 500 | 2000 | 77/65 | 377 | 36 |
| H20 | 0.218 | 3450/1725 | 3.6/1.8 | 500 | 2000 | 81/69 | 377 | 41 |
| H25 | 0.218 | 3450/1725 | 3.6/1.8 | 500 | 2000 | 86/73 | 377 | 50 |
| | 0.372 | 3450/1725 | 6.2/3.1 | 500 | 2000 | 86/73 | 377 | 50 |
| H45 | 0.218 | 1750/1140 | 1.8/1.2 | 500 | 2000 | 83/74 | 377 | 57 |
| | 0.372 | 1750/1140 | 3.1/2.1 | 1050/500 | 2000 | 83/74 | 377 | 57 |
| H55 | 0.372 | 1750/1140 | 3.1/2.1 | 650/500 | 2000 | 86/75 | 377 | 127 |
| | 0.5 | 1750/1140 | 4.2/2.7 | 500 | 3500 | 86/75 | 377 | 127 |
| H75 | 0.372 | 1750/1140 | 3.1/2.1 | 650/500 | 2000 | 88/79 | 377 | 159 |
| | 0.5 | 1750/1140 | 4.2/2.7 | 500 | 3500 | 88/79 | 377 | 159 |
| H100 | 0.372 | 1750/1140 | 3.1/2.1 | 1160/500 | 2000 | 92/83 | 377 | 195 |
| | 0.5 | 1750/1140 | 4.2/2.7 | 870/500 | 3500 | 92/83 | 377 | 195 |
| H140 | 0.5 | 1750/1140 | 4.2/2.7 | 1440/560 | 3500 | 92/83 | 377 | 230 |
| | 1.4 | 1750/1140 | 11.8/7.7 | 520/500 | 2750 | 92/83 | 377 | 230 |
| H180 | 0.5 | 1750/1140 | 4.2/2.7 | 1440/560 | 3500 | 94/85 | 377 | 267 |
| | 1.4 | 1750/1140 | 11.8/7.7 | 520/500 | 2750 | 94/85 | 377 | 267 |
| H210 | 0.5 | 1750/1140 | 4.2/2.7 | 1440/650 | 3500 | 95/86 | 377 | 280 |
| | 1.4 | 1750/1140 | 11.8/7.7 | 520/500 | 2750 | 95/86 | 377 | 280 |
| H260 | 0.5 | 1750/1140 | 4.2/2.7 | 2300/1000 | 3500 | 97/88 | 377 | 405 |
| | 1.4 | 1750/1140 | 11.8/7.7 | 825/500 | 2750 | 97/88 | 377 | 405 |
| H300 | 1.4 | 1750/1140 | 11.8/7.7 | 1010/525 | 2750 | 98/89 | 250 | 500 |
| | 1.95 | 1750/1140 | 16.4/10.7 | 725/500 | 3500 | 98/89 | 250 | 500 |
| H400 | 1.4 | 1750/1140 | 11.8/7.7 | 1630/765 | 2750 | 101/92 | 250 | 590 |
| | 1.95 | 1750/1140 | 16.4/10.7 | 1170/550 | 3500 | 101/92 | 250 | 590 |
| H500 | 1.4 | 1750/1140 | 11.8/7.7 | 1600/735 | 2750 | 101/92 | 250 | 650 |
| | 1.95 | 1750/1140 | 16.4/10.7 | 1150/530 | 3500 | 101/92 | 250 | 650 |

All data based at nominal speed

H SERIES DIMENSIONS

| Model Size | A | B | C (Approx.) | D | E | F | G | H | J | K | L | M | P |
|------------|-------|-------|-------------|-------|-------|------|----------------------------|-------|-------|-------|----------------------------------|------------------------|----------------------------|
| H10 | 13.74 | 13.78 | 10.00 | 11.38 | 4.37 | 1.97 | #12 SAE 1 1/16-12 UN-2B | 11.93 | 7.09 | 8.66 | M6-1 X12MM Bolt (4 PL) | Ø 0.55 | #8 SAE 3/4-16 UN-2B |
| H14 | 14.25 | 13.78 | 11.00 | 11.85 | 4.84 | 2.48 | #12 SAE 1 1/16-12 UN-2B | 11.93 | 7.09 | 8.66 | M8-1.25 X16MM Bolt (4 PL) | Ø 0.55 | #8 SAE 3/4-16 UN-2B |
| H20 | 15.91 | 15.75 | 10.00 | 12.54 | 4.87 | 1.50 | #16 SAE 1 5/16-12 UN-2B | 13.86 | 7.09 | 8.66 | | Ø 0.55 | #8 SAE 3/4-16 UN-2B |
| H25 | 15.91 | 16.54 | 11.20 | 12.15 | 5.26 | 1.50 | #16 SAE 1 5/16-12 UN-2B | 14.65 | | | Ø 0.55 | #8 SAE 3/4-16 UN-2B | |
| H45 | 19.60 | 21.65 | 11.10 | 16.24 | 4.87 | 1.50 | #20 SAE 1 5/8-12 UN-2B | 19.76 | 10.24 | 11.81 | M10-1.5 X20MM Bolt (8 PL) | Ø 0.55 | #8 SAE 3/4-16 UN-2B |
| H55 | 24.03 | 25.59 | 11.00 | 20.63 | 4.88 | 1.50 | #20 SAE 1 5/8-12 UN-2B | 23.70 | | | | Ø 0.55 | #12 SAE 1 1/16-12 UN-2B |
| H75 | 24.03 | 26.38 | 12.30 | 17.68 | 7.84 | 1.50 | #20 SAE 1 5/8-12 UN-2B | 24.49 | 10.24 | 11.81 | M12-1.75 X25MM Bolt (8 PL) | Ø 0.55 | #12 SAE 1 1/16-12 UN-2B |
| H100 | 25.89 | 30.31 | 12.20 | 19.50 | 7.84 | 1.50 | #20 SAE 1 5/8-12 UN-2B | 28.32 | | | | Ø 0.55 | #12 SAE 1 1/16-12 UN-2B |
| H140 | 30.19 | 36.22 | 13.56 | 23.00 | 10.69 | 1.50 | 2" SAE 4-Bolt FLANGE | 34.22 | 21.10 | 22.64 | M12-1.75 X25MM Bolt (8 PL) | Ø 0.55 | #12 SAE 1 1/16-12 UN-2B |
| H180 | 30.19 | 37.01 | 15.06 | 21.00 | 10.69 | 1.50 | | 35.01 | 21.10 | 22.64 | | Ø 0.55 | #12 SAE 1 1/16-12 UN-2B |
| H210 | 33.26 | 38.98 | 16.00 | 24.07 | 10.69 | 1.50 | | 36.98 | 21.10 | 22.64 | | Ø 0.55 | #12 SAE 1 1/16-12 UN-2B |
| H260 | 37.56 | 40.94 | 17.80 | 29.27 | 9.80 | 1.50 | | 39.06 | 21.10 | 22.64 | | Ø 0.55 | #12 SAE 1 1/16-12 UN-2B |
| H300 | 38.40 | 43.62 | 19.88 | 31.27 | 9.94 | 2.00 | 3" SAE 4-Bolt FLANGE | 40.17 | 14.72 | 17.72 | 3/4-10 x 1.75 Bolt (8 PL) | Ø 0.75 | #16 SAE 1 5/16-12 UN-2B |
| H400 | 46.96 | 49.49 | 20.79 | 36.03 | 12.73 | 2.00 | | 48.22 | 15.70 | 18.70 | | Ø 0.75 | #16 SAE 1 5/16-12 UN-2B |
| H500 | 59.76 | 53.68 | 18.78 | 43.62 | 17.56 | 2.00 | | 50.34 | 17.67 | 20.67 | | Ø 0.75 | #16 SAE 1 5/16-12 UN-2B |

All dimensions in inch

COOLER DIMENSIONS H

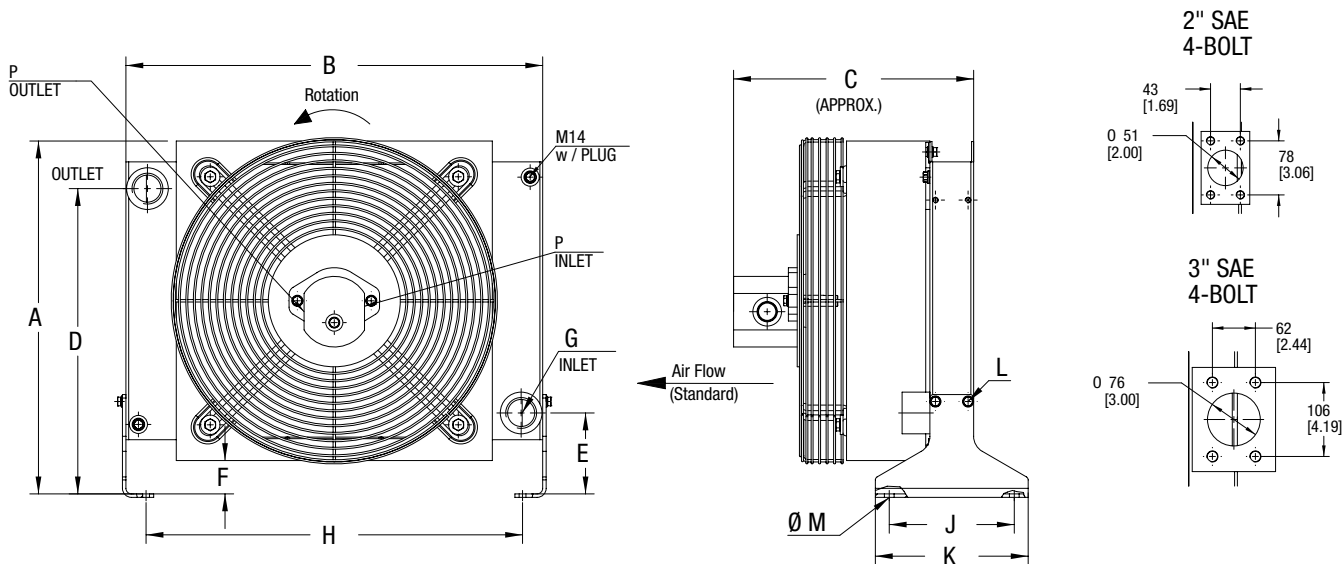

SELECTION PROCEDURES

The performance curves are based on the following:

- 50 SUS Oil
- 100 °F Entering Temperature Difference (ETD)

If your application conditions are different, use the following selection procedure:

STEP 1. DETERMINE THE HEAT LOAD

Horsepower Heat x 2545 = BTU/hr

STEP 2. DETERMINE THE ACTUAL ETD DESIRED

Entering OIL Temperature - Entering AIR Temperature = ETD

The entering oil temperature is the highest desired oil temperature. The entering air temperature is the highest anticipated ambient air temperature, plus any pre-heating of the air prior to its entering the cooler. This is especially important if air is drawn from the engine compartment for cooling.

STEP 3. CALCULATE THE ADJUSTED BTU/HR FOR SELECTION

$$\text{BTU/hr Heat Load} \times \frac{100}{\text{Desired ETD}} = \text{BTU/hr For Use With Selection Chart}$$

STEP 4. SELECT THE MODEL FROM THE CURVES

Read up from the GPM to the required heat rejection. Select any model on, or above this point.

ORDERING INFORMATION

SERIES CODE: MODEL SIZE: MOTOR CODE: BYPASS DATA: CUSTOM FEATURE CODE:

| | | | | | |
|--|--|---|--|--|--|
| | | — | | | |
|--|--|---|--|--|--|

SERIES: H = Optimized
 MODEL SIZE: Selected
 MOTOR CODE: 0 = No Motor ; 0218 = 0.218 cu-in; 0372 = 0.372 cu-in; 0050 = 0.50 cu-in; 0140 = 1.40 cu-in; 0195 = 1.95 cu-in
 BYPASS DATA: BPNV = Bypass No Valve, BP25 = 25PSI Internal Bypass, BP30 = 30PSI Internal Bypass, BP60 = 60PSI Internal Bypass, BP65 = 65PSI Internal Bypass,
 CUSTOM FEATURE CODE: B = Blowing Fan, AD = SAE to NPT Adaptors, H = Heresite Coating Core, F = Foam Filter

ORDER EXAMPLE: Heat Exchanger, 75 HP; Suction Fan, No Motor; 60PSI Internal Bypass H75-0-BP60



AKG Thermal Systems, Inc.
809 Mattress factory Road
P.O. Box 189
Mebane, NC 27302-0189
USA
Tel: +1 919-563-48-71
Fax: +1 919-563-49-17
E-Mail: sales@akgts.com
Internet: www.akgts.com

AKG – A STRONG GLOBALLY INTEGRATED GROUP OF COMPANIES

AKG is a globally leading supplier of high-performance coolers and heat exchangers as well as customised system solutions, that comply with the highest quality standards.

On a world-wide scale, 2,800 employees work at 12 manufacturing facilities located in Germany, France, United Kingdom, Latvia, the U.S.A., China and India. Together with a number of additional oversea sales companies they are on duty around the clock.

Your AKG-Partner

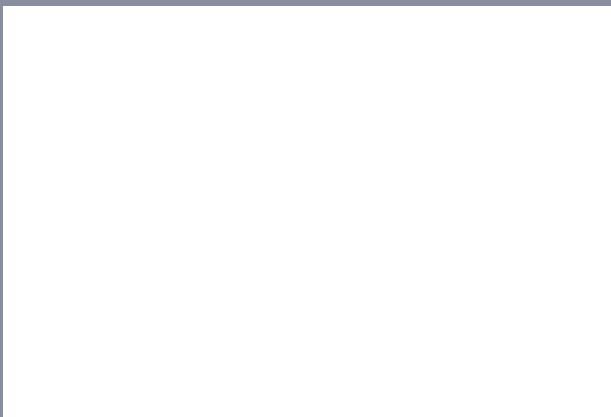

The longstanding and competent partnership with global OEM customers from 22 lines of business such as construction machinery, compressed-air systems, agricultural and forestry machines, vehicle construction and many other fields of application give fresh and innovative impetus to the mobile and industrial standard type series.

AKG operates one of the world's largest research, development, measurement and validation centres for cooling solutions and customised applications.

For 90 years AKG's heat exchangers have stood for innovative solutions as well as highest engineering and manufacturing competence.

Aluminum Coolers – Made by AKG
DIN EN ISO 9001 : 2000