



SERIES

Oil Coolers

- ▶ New DCS Dual Fan models for 45HP and 60HP cooling performance
- ▶ All DC/DCS and Dual Fan models available with internal pressure bypass
- ▶ DC Motor Driven Cooling Fans Are A Low Cost Solution To Remote Cooler Mounting Requirements.
- ▶ DCS Models include a shroud between the cooler and fan to enhance performance.
- ▶ Competitive Pricing, Deliveries From Stock.
- ▶ Optional New Temperature Controller or Existing Temperature Switch Cycles Cooling Fan To Maintain Desired Oil Temperature



Selection Procedures

The performance curves above are based on the following:

- 50 SUS Oil.
- 100°F Entering Temperature Difference (ETD)

If your application conditions are different, use the following selection procedure:

STEP 1. Determine the Heat Load

$$\text{Horsepower Heat} \times 2545 = \text{BTU/hr}$$

STEP 2. Determine the Actual ETD Desired

$$\text{Entering OIL Temperature} - \text{Entering AIR Temperature} = \text{ETD}$$

The entering oil temperature is the highest desired oil temperature. The entering air temperature is the highest anticipated ambient air temperature, plus any pre-heating of the air prior to its entering the cooler. This is especially important if air is drawn from the engine compartment for cooling.

STEP 3. Calculate the Adjusted BTU/hr for Selection

$$\frac{\text{BTU/hr}}{\text{Heat Load}} \times \frac{100}{\text{Desired ETD}} = \text{BTU/hr For Use With Selection Chart}$$

STEP 4. Select The Model From The Curves

Read up from the GPM to the required heat rejection. Select any model on, or above this point.

STEP 5. Calculate Oil Pressure Drop

Find the oil pressure drop correction factor and multiply it by the oil pressure drop found on the performance curve.

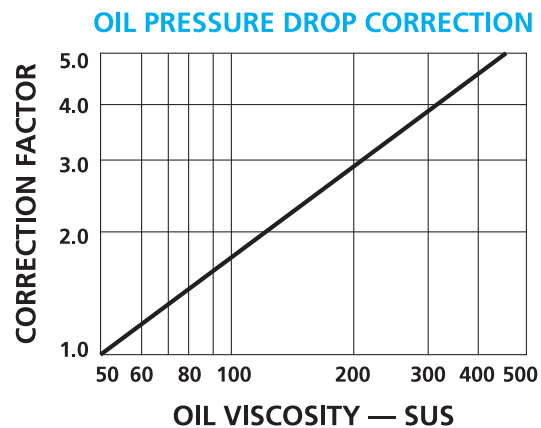

Features

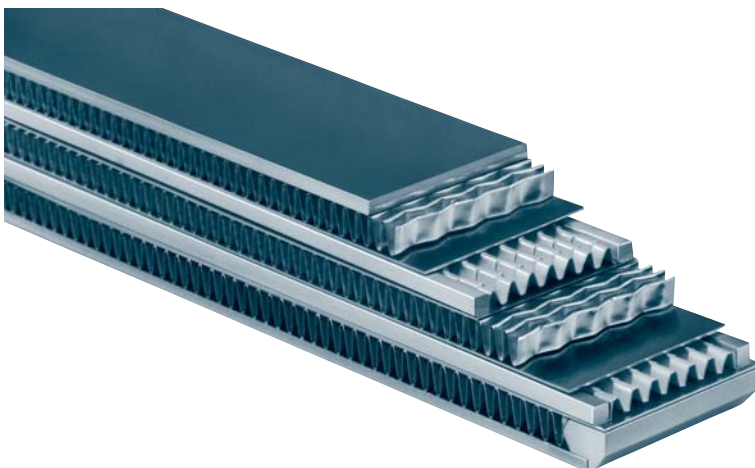

- ▶ **New Dual Fan Models**
- ▶ **Internal Pressure Bypass available for all models**
- ▶ **Advanced Technology Designs**
- ▶ **Leak Free SAE O-Ring Connections**
- ▶ **Rugged Bar & Plate Design**
- ▶ **Reduced Air Side Fouling**
- ▶ **Wide Selection of Standard Models**
- ▶ **Sturdy Long Life DC Fan Motors with Packard connections**

Performance

OIL COOLER PERFORMANCE

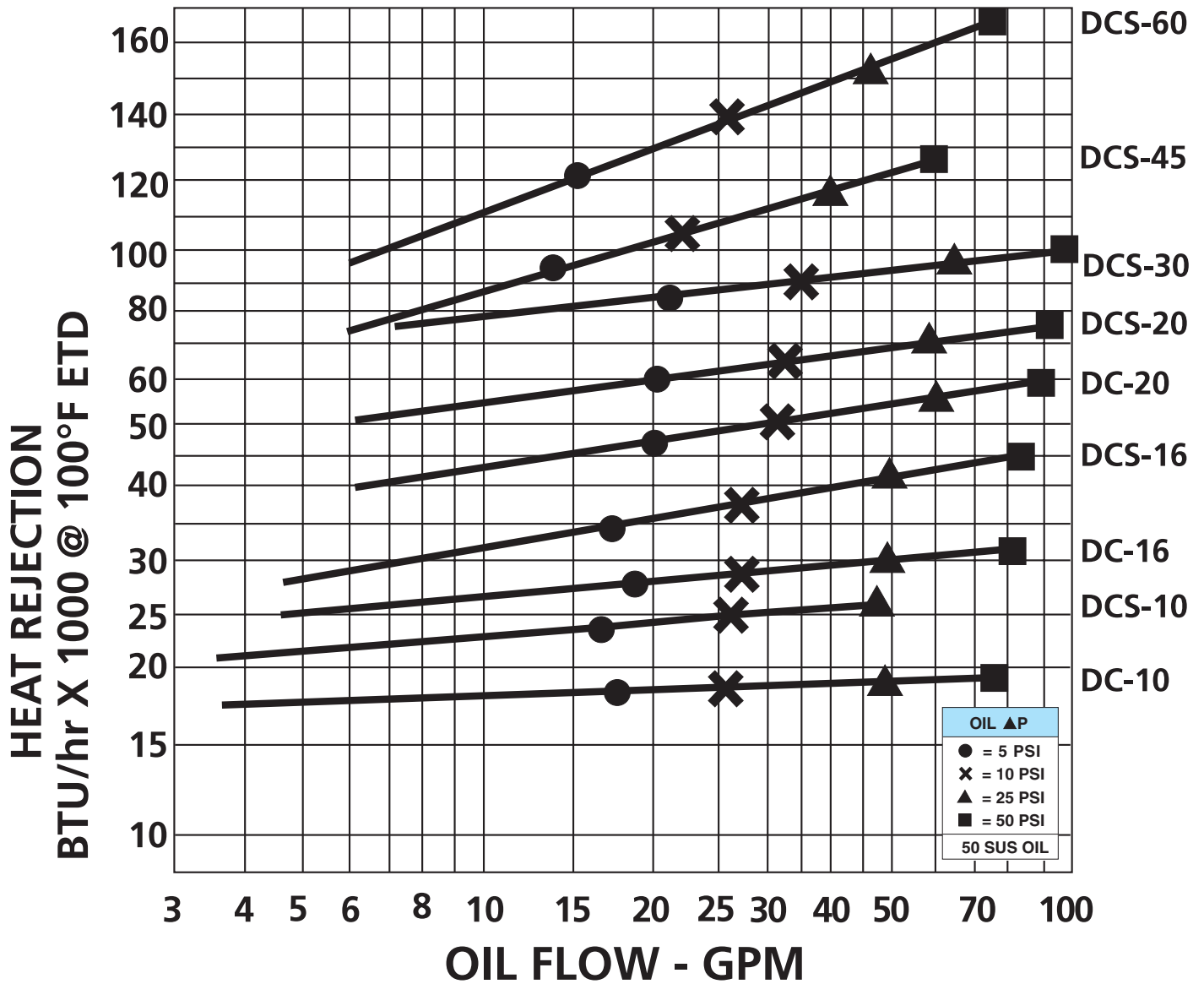

Note: DCS models with shroud have up to 40% more performance than DC models.

Specifications

RATINGS

MAXIMUM WORKING PRESSURE250 PSI

MAXIMUM WORKING TEMPERATURE250 °F

MATERIALS

COOLERAluminum

FAN BLADEPlastic

FAN GUARDPlastic

MOTORPainted Steel

SHROUDPowder Painted Steel

Dimensions

Standard DC Series

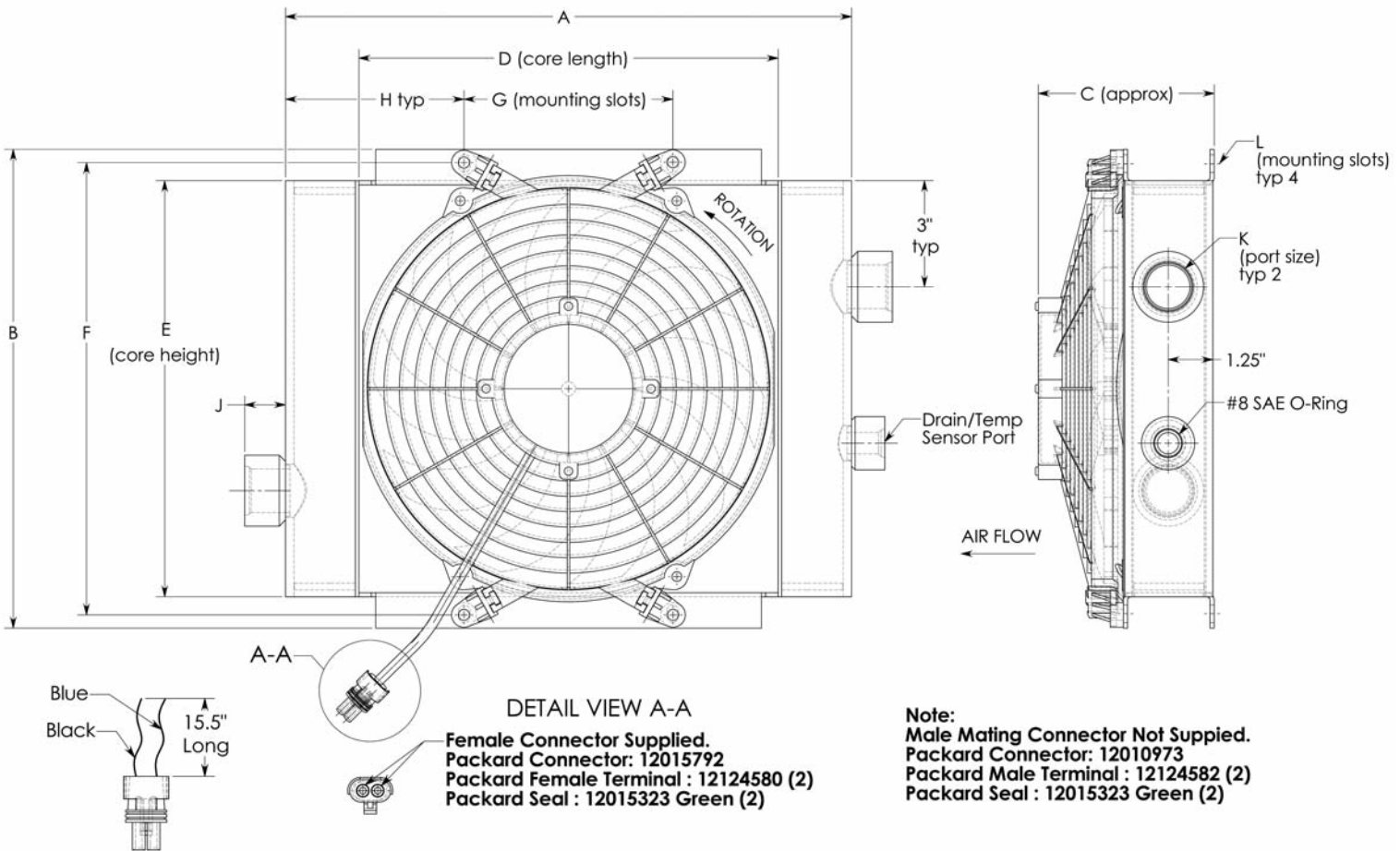

MODEL NUMBER	A	B	C	D	E	F	G	H	J	K	L	Amp Draw		Approx. Shipping Weight (lbs)
												12V	24V	
DC-10	13.98	11.73	4.84	9.84	9.96	10.87	4.96	4.49	1.00	#12 SAE O-Ring	5/16 x 1/2" slot	5.2	2.6	19.0
DC-16	15.94	13.5	5.04	11.81	11.81	12.76	5.87	5.04	1.14	#16 SAE O-Ring	5/16 x 1/2" slot	8.2	4.1	23.0
DC-20	19.69	18.43	5.31	15.75	16.14	17.32	12.00	3.86	1.57	#20 SAE O-Ring	7/16 x 3/4" slot	19.0	9.5	28.0

*Note: All dimensions in inches.

*Note: We reserve the right to make reasonable design changes without notice.

Ordering Information



DC SERIES

MODEL SIZE
SELECTED

MOTOR DATA
12 = 12 VOLT
24 = 24 VOLT

OPTIONS

TC115 = 115°F Temperature Sensor Installed
 TC140 = 140°F Temperature Sensor Installed
 AD = SAE to NPT Adaptors Installed

Dimensions

DCS Series with Fan Shroud

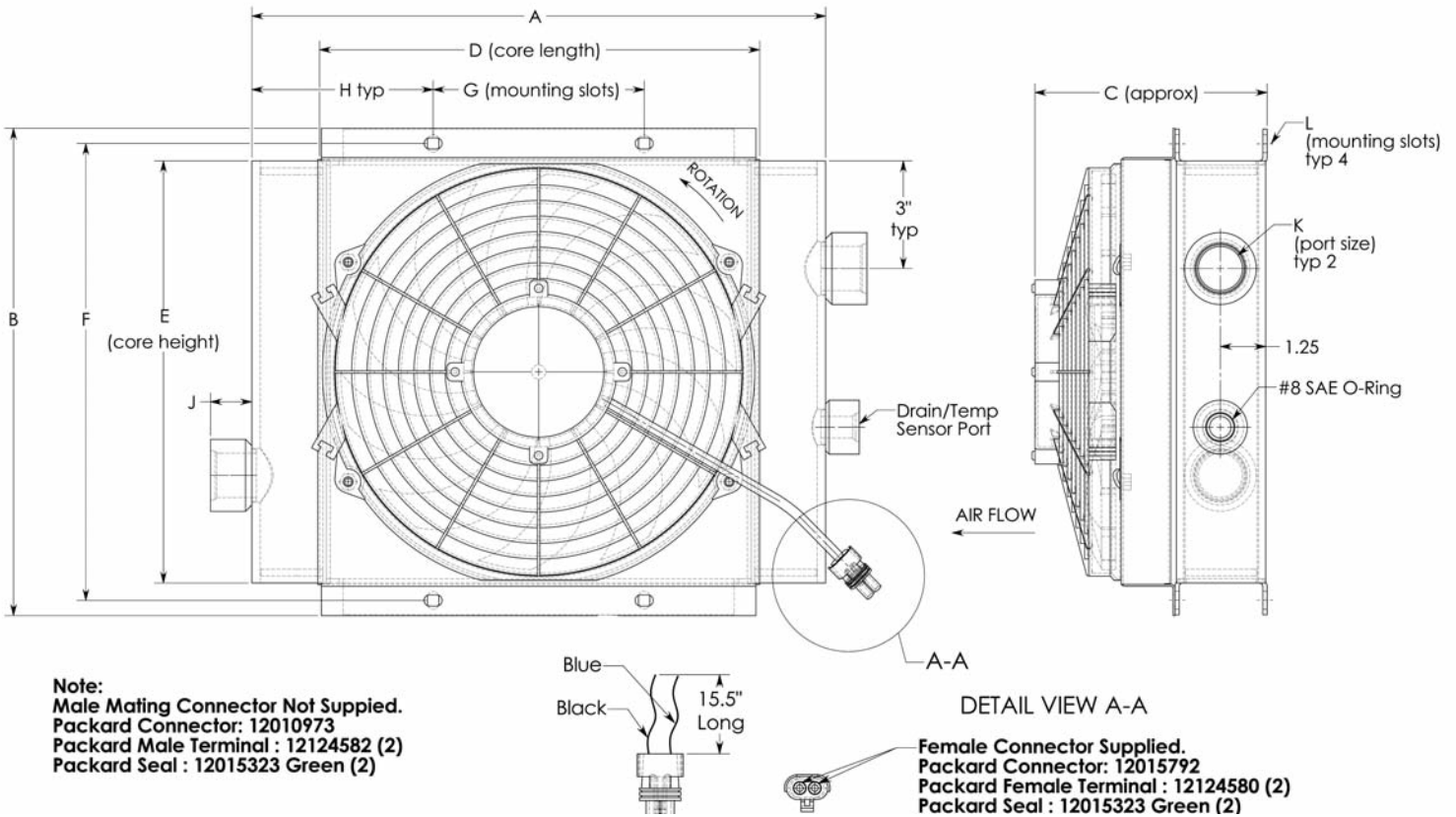

MODEL NUMBER	A	B	C	D	E	F	G	H	J	K	L	Amp Draw		Approx. Shipping Weight (lbs)
												12V	24V	
DCS-10	13.98	11.73	6.3	9.84	9.96	10.87	4.96	4.49	1.00	#12 SAE O-Ring	5/16 x 1/2" slot	5.2	2.6	20.0
DCS-16	15.94	13.5	6.46	11.81	11.81	12.76	5.87	5.04	1.14	#16 SAE O-Ring	5/16 x 1/2" slot	8.2	4.1	25.0
DCS-20	19.69	18.43	7.2	15.75	16.14	17.32	12.00	3.86	1.57	#20 SAE O-Ring	7/16 x 3/4" slot	19.0	9.5	31.0
DCS-30	23.62	22.13	7.2	19.69	19.84	21.02	15.98	3.86	1.57	#20 SAE O-Ring	7/16 x 3/4" slot	19.0	9.5	53.0

*Note: All dimensions in inches.

*Note: We reserve the right to make reasonable design changes without notice.

Ordering Information



DCS SERIES

MODEL SIZE
SELECTED

MOTOR DATA
12 = 12 VOLT
24 = 24 VOLT

OPTIONS

TC115 = 115°F Temperature Sensor Installed
 TC140 = 140°F Temperature Sensor Installed
 AD = SAE to NPT Adaptors Installed

Dimensions

DC Series with Bypass

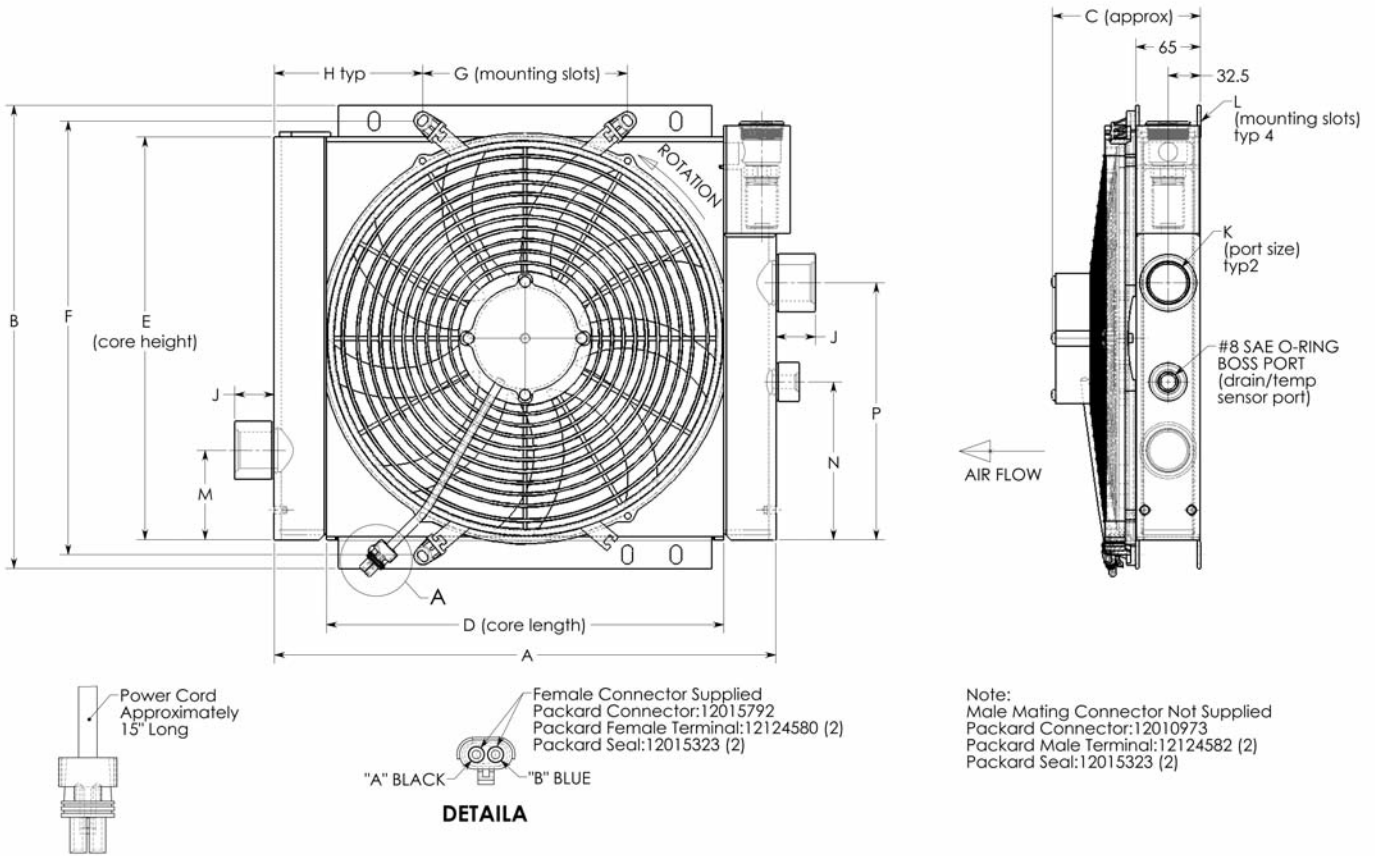

MODEL NUMBER	A	B	C	D	E	F	G	H	J	K	L	M	N	P	AMP DRAW		Approx. Shipping Weight (lbs.)
															12V	24V	
DC-10	13.98	11.73	4.84	9.84	9.96	10.87	4.96	4.49	1.00	#12 SAE O-Ring	5/16 x 1/2" slot	2.99	1.22	4.17	5.2	2.6	20.5
DC-16	15.94	13.5	5.04	11.81	11.81	12.76	5.87	5.04	1.14	#16 SAE O-Ring					3.54	3.03	
DC-20	19.69	18.43	5.31	15.75	16.14	17.32	12.00	3.86	1.57	#20 SAE O-Ring	7/16 x 3.4" slot	3.54	6.26	10.2	19.0	9.5	29.5

*Note: All dimensions in inches. *Note: We reserve the right to make reasonable design changes without notice.

Ordering Information

DC SERIES Without Fan Shroud	MODEL SIZE	MOTOR DATA 12 = 12 Volt 24 = 24 Volt	BYPASS DATA BPNV = Bypass No Valve BP25 = 25 PSI INT Bypass BP65 = 65 PSI INT Bypass	OPTIONAL FEATURES TC115 = TC115 Shipped W/Cooler TC140 = TC140 Shipped W/Cooler AD = SAE to NPT Adaptors Shipped W/Cooler MTG = Foot Mounting Bracket Set

Dimensions

DCS Series with Bypass

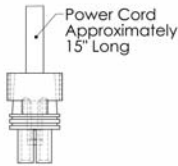
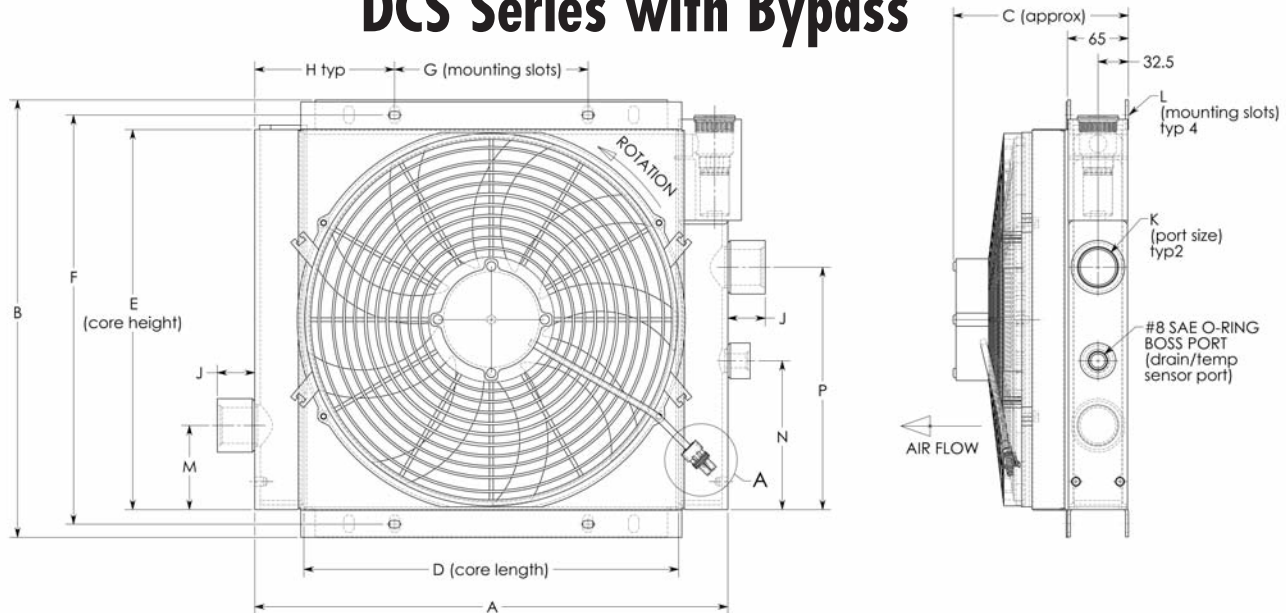

Note:
 Male Mating Connector Not Supplied
 Packard Connector: 12010973
 Packard Male Terminal: 12124582 (2)
 Packard Seal: 12015323 (2)

MODEL NUMBER	A	B	C	D	E	F	G	H	J	K	L	M	N	P	AMP DRAW		Approx. Shipping Weight (lbs.)
															12V	24V	
DCS-10	13.98	11.73	6.3	9.84	9.96	10.87	4.96	4.49	1.00	#12 SAE O-Ring	5/16 x 1/2" slot	2.99	1.22	4.17	5.2	2.6	21.5
DCS-16	15.94	13.5	6.46	11.81	11.81	12.76	5.87	5.04	1.14	#16 SAE O-Ring							
DCS-20	19.69	18.43	7.2	15.75	16.14	17.32	12.00	3.86	1.57	#20 SAE O-Ring	7/16 x 3.4" slot	3.54	6.26	10.2	19.0	9.5	32.5
DCS-20	23.62	22.13	7.2	19.69	19.84	21.02	15.98	3.86	1.57	#20 SAE O-Ring	7/16 x 3/4" slot						

*Note: All dimensions in inches. *Note: We reserve the right to make reasonable design changes without notice.

Ordering Information



DC SERIES
With Fan Shroud

MODEL SIZE

MOTOR DATA
12 = 12 Volt
24 = 24 Volt

BYPASS DATA
BPNV = Bypass No Valve
BP25 = 25 PSI INT Bypass
BP65 = 65 PSI INT Bypass

OPTIONAL FEATURES
TC115 = TC115 Shipped W/Cooler
TC140 = TC140 Shipped W/Cooler
AD = SAE to NPT Adaptors Shipped W/Cooler
MTG = Foot Mounting Bracket Set

Dimensions

Standard DCS Dual Fan Series

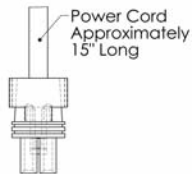
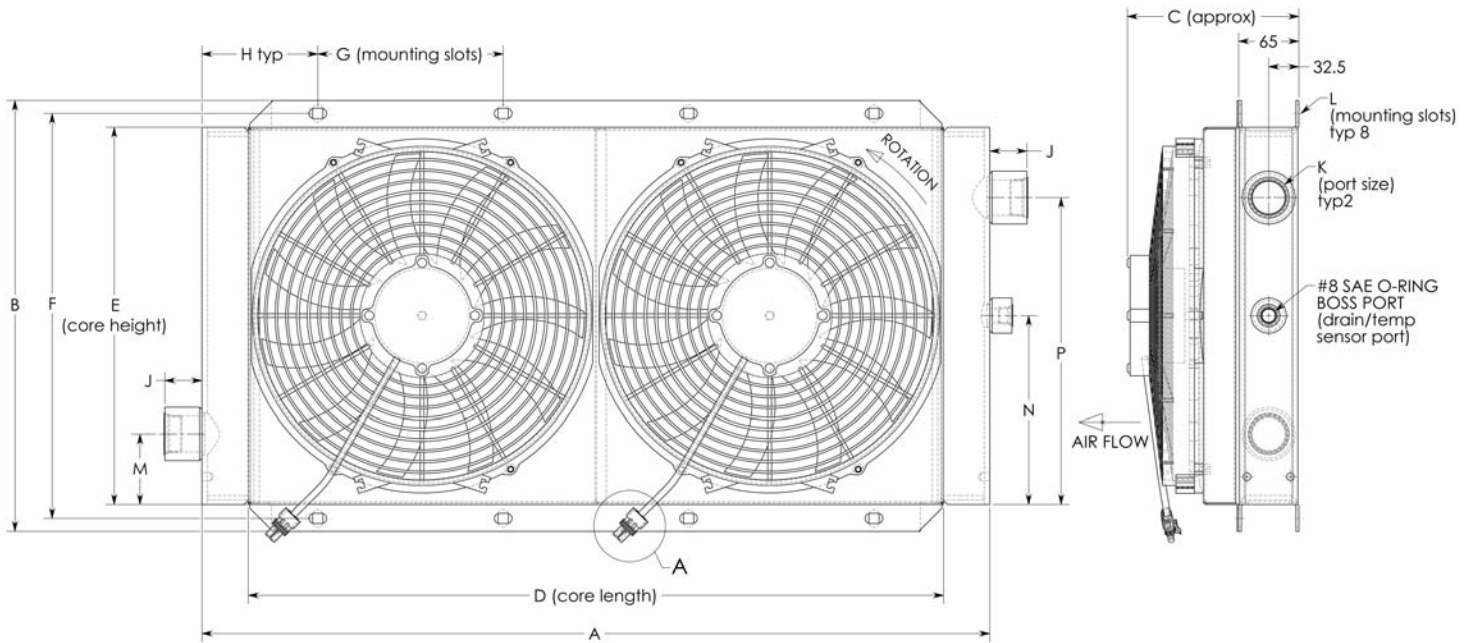

Note:
 Male Mating Connector Not Supplied
 Packard Connector: 12010973
 Packard Male Terminal: 12124582 (2)
 Packard Seal: 12015323 (2)

MODEL NUMBER	A	B	C	D	E	F	G	H	J	K	L	M	N	P	AMP DRAW		Approx. Shipping Weight (lbs.)
															12V	24V	
DCS-45	33.46	18.43	7.2	29.53	16.14	17.32	7.87	4.92	1.57	#20 SAE O-Ring	7/16 x 3/4" slot	2.99	8.01	13.03	36.2	18.1	65.0
DCS-60	35.43	22.13	7.2	31.49	19.84	21.02	8.86	4.43	1.57	#20 SAE O-Ring		2.99	9.86	16.73	38.0	19.0	109.0

*Note: All dimensions in inches. *Note: We reserve the right to make reasonable design changes without notice.

Ordering Information

DC SERIES With Fan Shroud	MODEL SIZE	MOTOR DATA 12 = 12 Volt 24 = 24 Volt	OPTIONAL FEATURES TC115 = TC115 Shipped W/Cooler TC140 = TC140 Shipped W/Cooler AD = SAE to NPT Adaptors Shipped W/Cooler MTG = Foot Mounting Bracket Set

Dimensions

DCS Dual Fan Series with Bypass

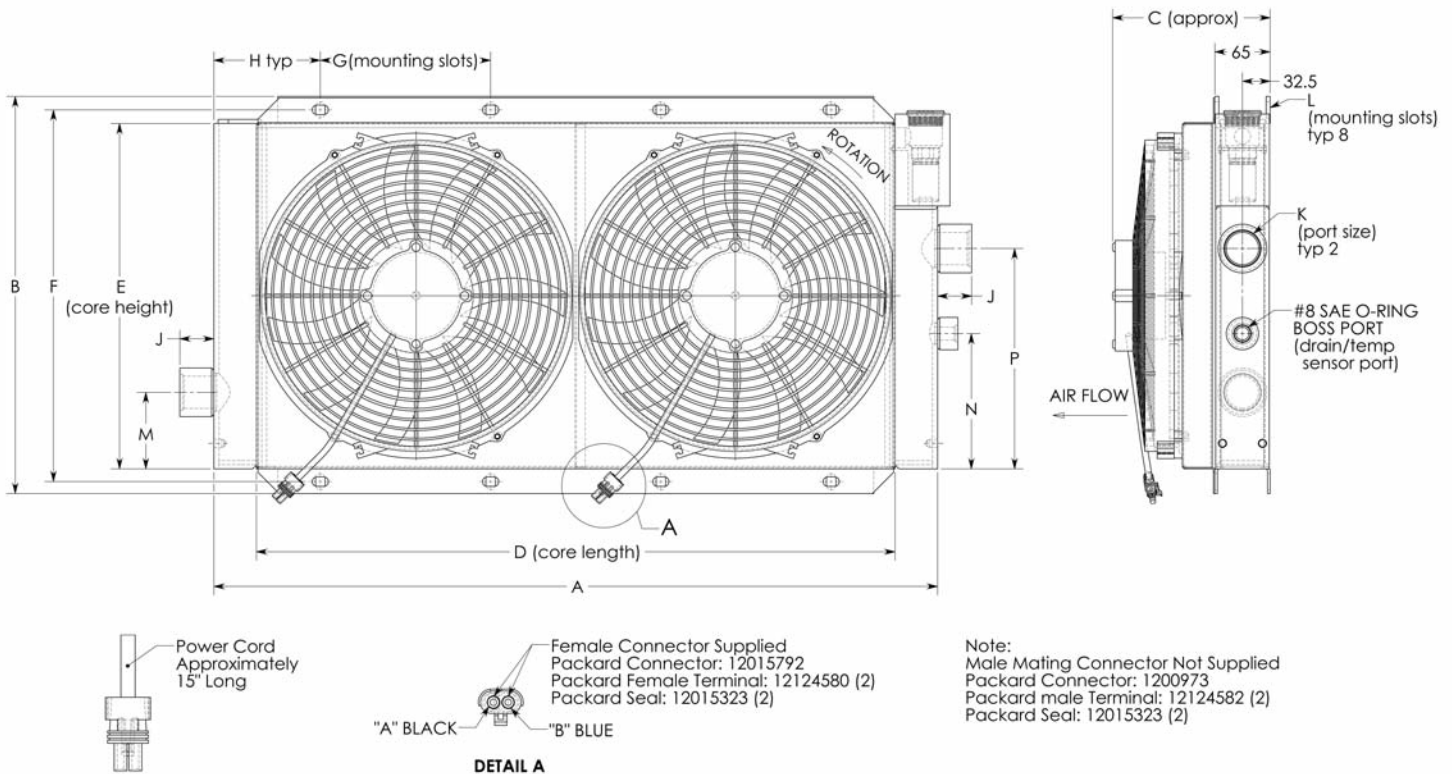

MODEL NUMBER	A	B	C	D	E	F	G	H	J	K	L	M	N	P	AMP DRAW		Approx. Shipping Weight (lbs.)
															12V	24V	
DCS-45	33.46	18.43	7.2	29.53	16.14	17.32	7.87	4.92	1.57	#20 SAE O-Ring	7/16 x 3/4" slot	3.54	6.26	10.2	36.2	18.1	67.0
DCS-60	35.43	22.13	7.2	31.49	19.84	21.02	8.86	4.43	1.57	#20 SAE O-Ring		3.54	8.9	12.83	38.0	19.0	111.0

*Note: All dimensions in inches. *Note: We reserve the right to make reasonable design changes without notice.

Ordering Information

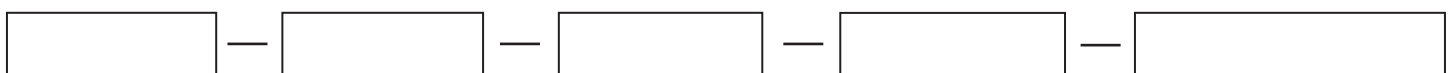

DC SERIES
With Fan Shroud

MODEL SIZE

MOTOR DATA
12 = 12 Volt
24 = 24 Volt

BYPASS DATA
BPNV = Bypass No Valve
BP25 = 25 PSI INT Bypass
BP65 = 65 PSI INT Bypass

OPTIONAL FEATURES
TC115 = TC115 Shipped W/Cooler
TC140 = TC140 Shipped W/Cooler
AD = SAE to NPT Adaptors Shipped W/Cooler
MTG = Foot Mounting Bracket Set

M404 Temperature Controller

This controller is used to cycle DC Fan motors to provide accurate temperature control

- 12 or 24 Volt Operation
- Six different temperature settings to select
- Temperature Sensor provided
- Wiring provided for remote manual override
- Fan connector connects to mating DC Packard connector
- Weather sealed, Vibration resistant

Model Number
M404

Description
M404 Temperature Controller

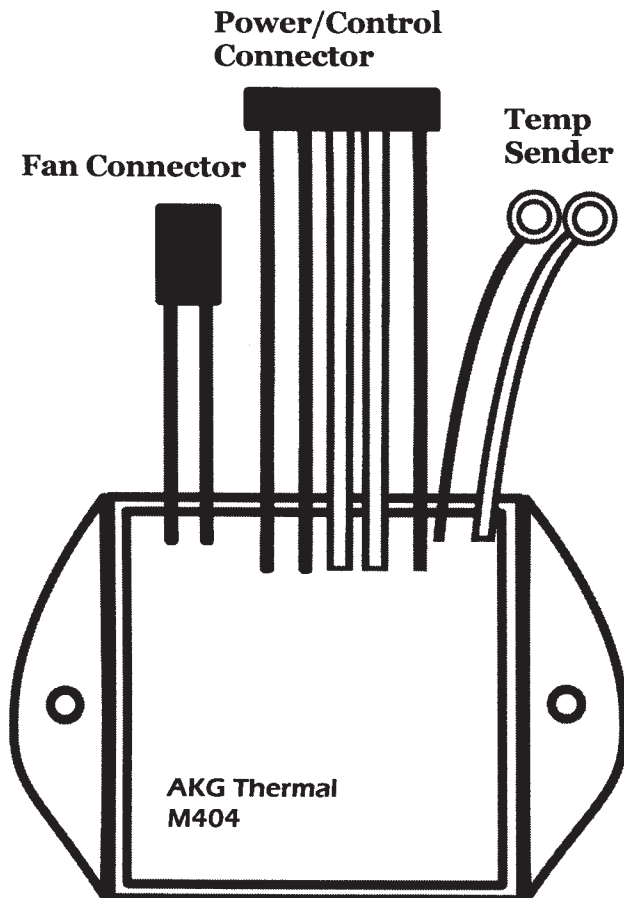

Fan Connector

Blue: +
Black: -

Temperature Sender

Black: Ground (Body)
White: Sender Terminal

Power Control Connector

Red: +12 to 24 Volts DC
Black: Ground (-)
White: Manual Override
Yellow/Orange: Temp Select (see below table)

Temp. (F)	TS1 (Yellow)	TS2 (Orange)
115	Black	No Conn.*
125	No Conn.*	No Conn.*
140	No Conn.*	Black
160	Red	No Conn.*
180	No Conn.*	Red
200	Black	Black

* wire should not be connected at this temperature setting

Optional Temperature Control Switch

Use these Temperature Switches to control oil temperature by cycling the cooling fan to maintain the desired entering, or leaving temperature. The Temperature Switches are designed to be installed in the drain ports of the DC Series Coolers, and in the reservoirs or piping of AC/ACD Series Coolers. Depending on how the cooler is plumbed, it can be used to control the temperature of the oil either entering, or leaving the cooler.

It is a normally open switch that closes on temperature rise.
Two Models to satisfy a wide range of applications.

Schematic

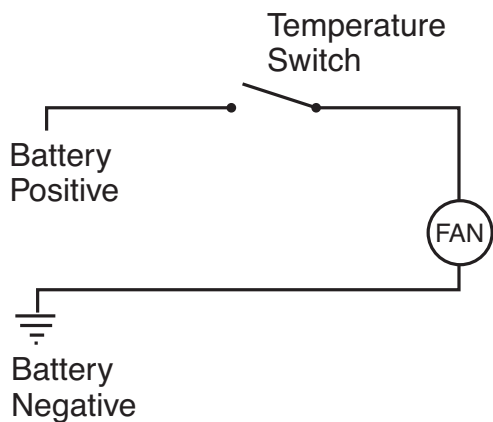

Specifications

TC -115 Set Point	115°F
TC -140 Set Point	140°F
Set Point Tolerance	±5°F
Maximum Temperature	325°F
Current Rating	10 Amps at 12 Volts 5 Amps at 24 Volts
Differential	8° - 16° F
Switch Body	Brass
Housing	Nylon

Dimensions

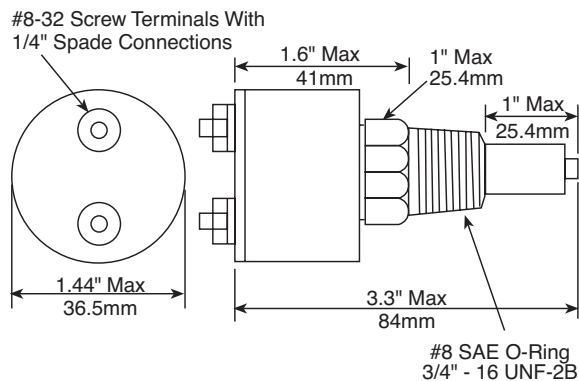

Model Numbers

TC -115

TC -140

AKG[®] **Worldwide**

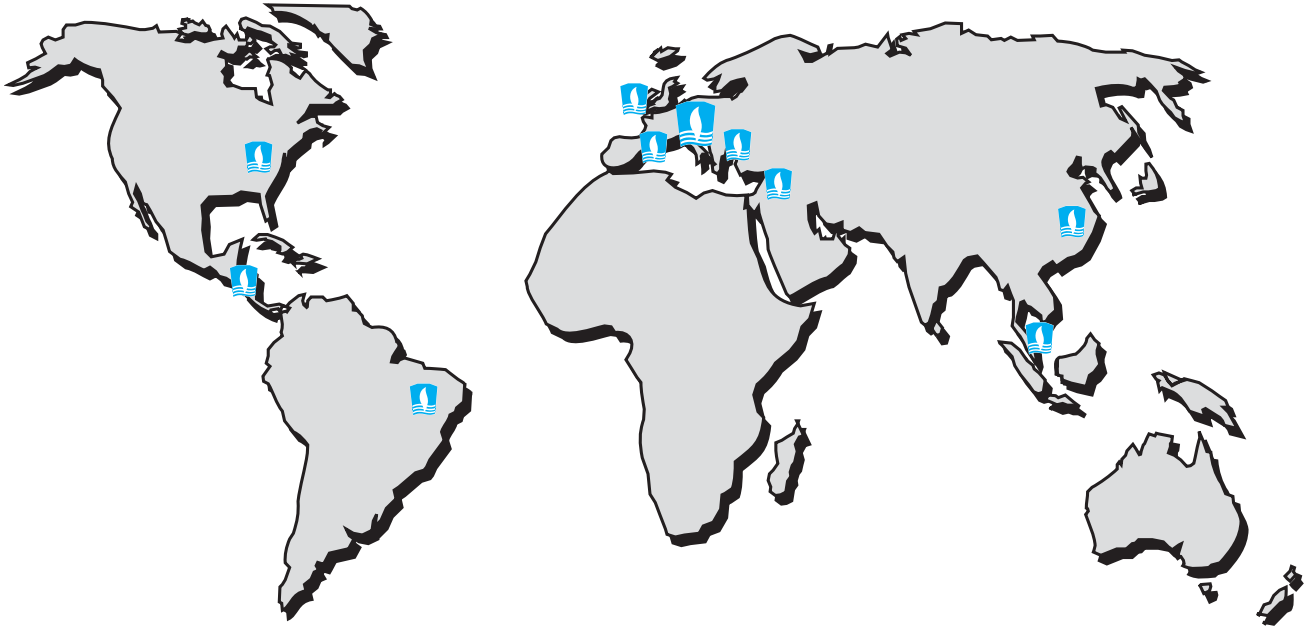

AKG has been manufacturing high quality coolers and cooling systems since 1919. We have grown to include 10 facilities with over 1400 employees to serve you.

Your Business Partner



AKG Worldwide

AKG is a complete single source supply for all of your cooling requirements. Choose from both standard and custom engineered products depending on your specific needs.



Partnership

AKG believes in solid long-term business relationships built on partnerships with its customers.



Customer

AKG places heavy emphasis on development of leading edge technologies, products and finding creative solutions to our customers individual requirements.

AKG Thermal Systems, Inc.
Mebane Industrial Park
809 Mattress Factory Road
P.O. box 189
Mebane, North Carolina 27302-0189
Tel.: (919) 563-4871
Fax: (919) 563-4917

Autokühler GmbH & Co. KG
Postfach 1346
D-34363 Hofgeismar
Tel.: 05671 / 8 83-0
Fax: 05671 / 35 82
Internet: <http://www.akg-gruppe.de>
E-mail: Info@akg-gruppe.de